

Technische Daten

Schrankspeicher

Type: SSP 120, 200, 250, 300



200-250-300 Liter

120 Liter

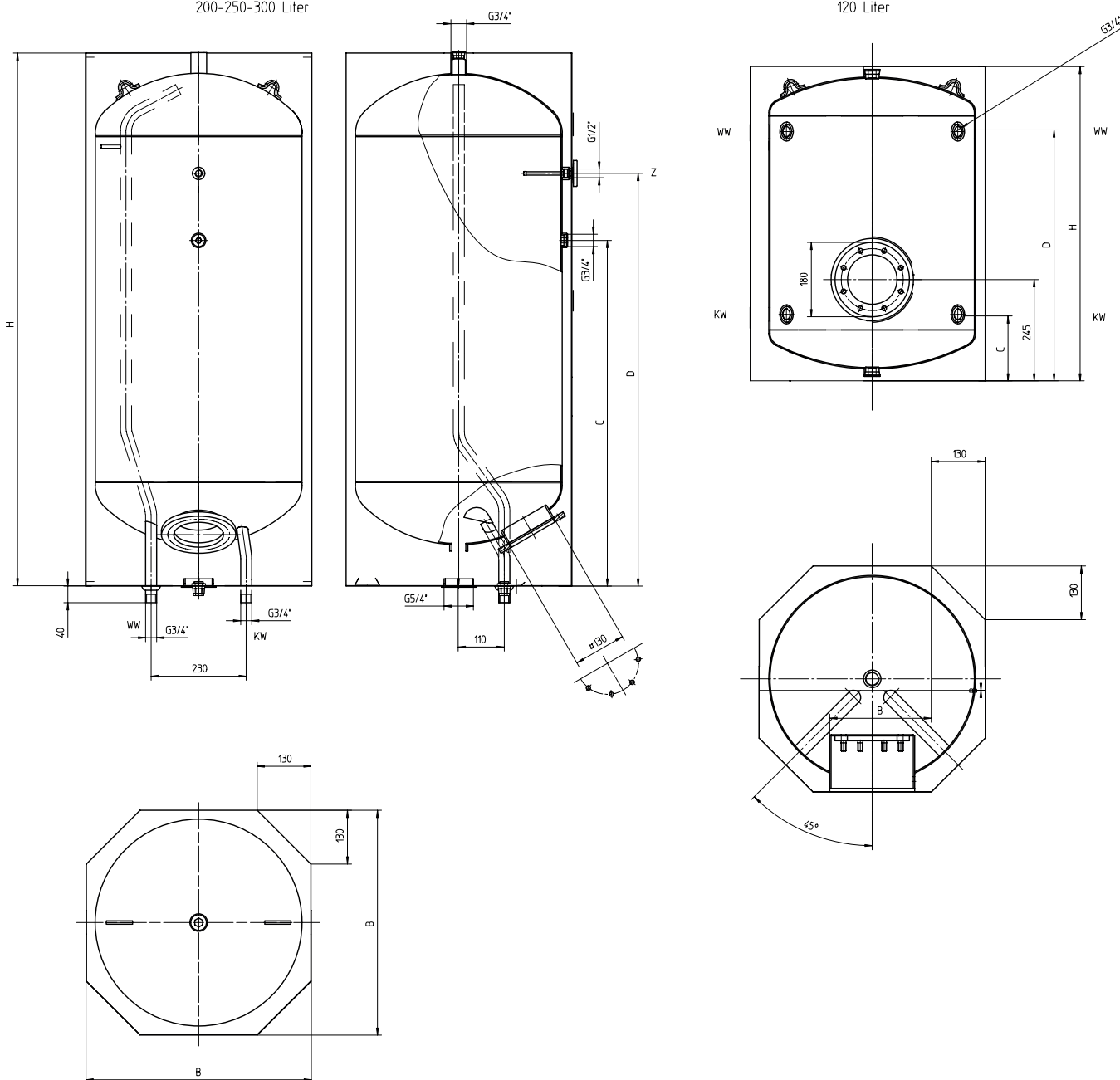

Type	Inhalt Liter	Abmessungen in mm				Leerge- wicht in kg	Bereitschafts- energieverbrauch kWh/24h	Warmhalte- verlust W	Energieeffizi- enzklasse
		B	H	C	D				
SSP 120	120	545	760	160	603	67	1,49	62	C
SSP 200	200	545	1290	836	998	83	1,76	73	C
SSP 250	250	545	1545	986	1180	106	2,13	89	C
SSP 300	300	545	1730	1103	1323	115	2,22	93	C

Technical data

Hot water tank

Type: SSP 120, 200, 250, 300



200-250-300 Liter

120 Liter

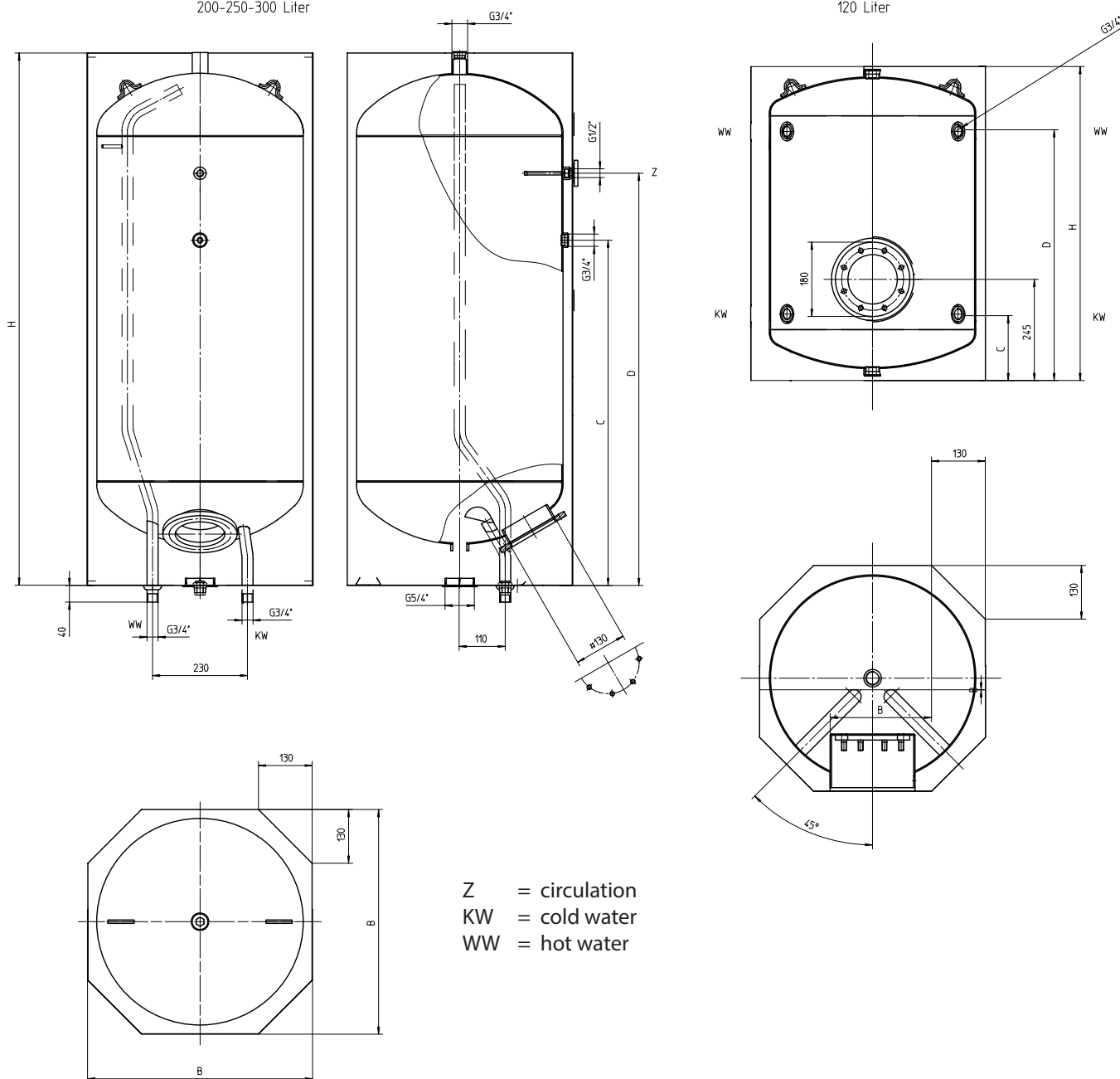

Type	Volume	Dimensions in mm				Weight kg	Stand-by energy consumption kWh/24h	Standing loss W	Energy efficiency class
		B	H	C	D				
SSP 120	120	545	760	160	603	67	1,49	62	C
SSP 200	200	545	1290	836	998	83	1,76	73	C
SSP 250	250	545	1545	986	1180	106	2,13	89	C
SSP 300	300	545	1730	1103	1323	115	2,22	93	C